

# DZ10U

## Diaz

Oliveri®

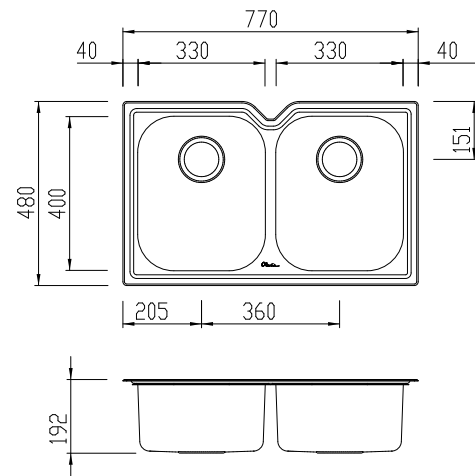

### INCLUDED ACCESSORIES



### RECOMMENDED TAPWARE



### OPTIONAL ACCESSORIES



### SPECIFICATIONS

#### Description

Double bowl undermount sink

#### Sink Size

770W x 480H

#### Main Bowl

330W x 400H x 180D / 21L

#### Main Bowl

330W x 400H x 180D / 21L

#### Construction

2 piece, bowls & drainer seam welded

#### Material

304 grade, 18/10 polished stainless steel (0.8mm thick)

#### Installation

Undermount recommended.

#### Fixings

n/a

#### Cut Out Template

oliverisinks.com

#### Min Cabinet Size

800mm

#### Tap holes

n/a

#### Waste fittings

2 x 90mm basket wastes included

#### Overflow

Not available

#### Carton Size

837 x 547 x 237mm

#### Weight

6.0kg

#### Warranty

Lifetime manufacturer's warranty (refer to oliverisinks.com)

For more information call **1300 13 7465** or visit **www.oliverisinks.com**

